

TIME'S UP

KUNSTSAMMLUNG & UNIKATE



TIME'S UP
LABOR ZUR SCHAFFUNG EXPERIMENTELLER SITUATIONEN
INDUSTRIEZEILE 33B • A-4020 LINZ
[HTTPS://TIMESUP.ORG](https://timesup.org) • [INFO@TIMESUP.ORG](mailto:info@timesup.org)

↓ DETAILS ZUM EXPONAT



TIMEMACHINE (2010)

Exponat der Ausstellung '20 Seconds into the Future'
Sound, Audio- und Lichtskulptur, Stahlblech, Mikrokontroller
motorisiertes Drehteller, mechanische Pegelanzeigen

Dimensionen - Oktagon: 69 cm x 61 cm x 69 cm (Höhe, Breite, Tiefe); 230V

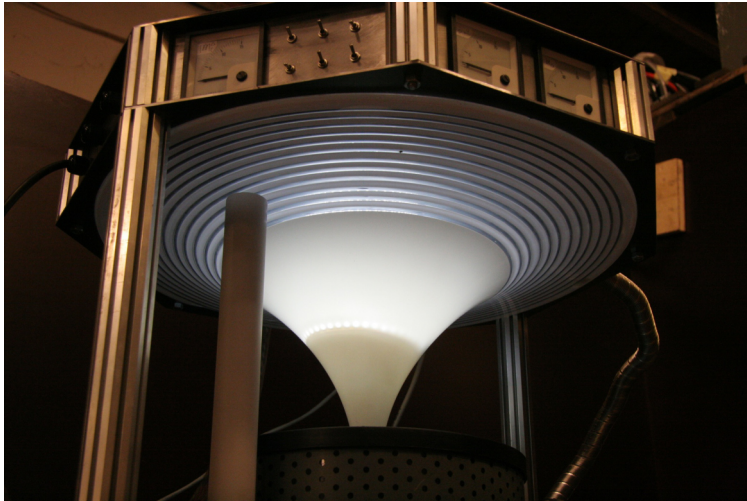

AUSSTELLUNGSANSICHTEN - JKU LINZ, AT (2010)

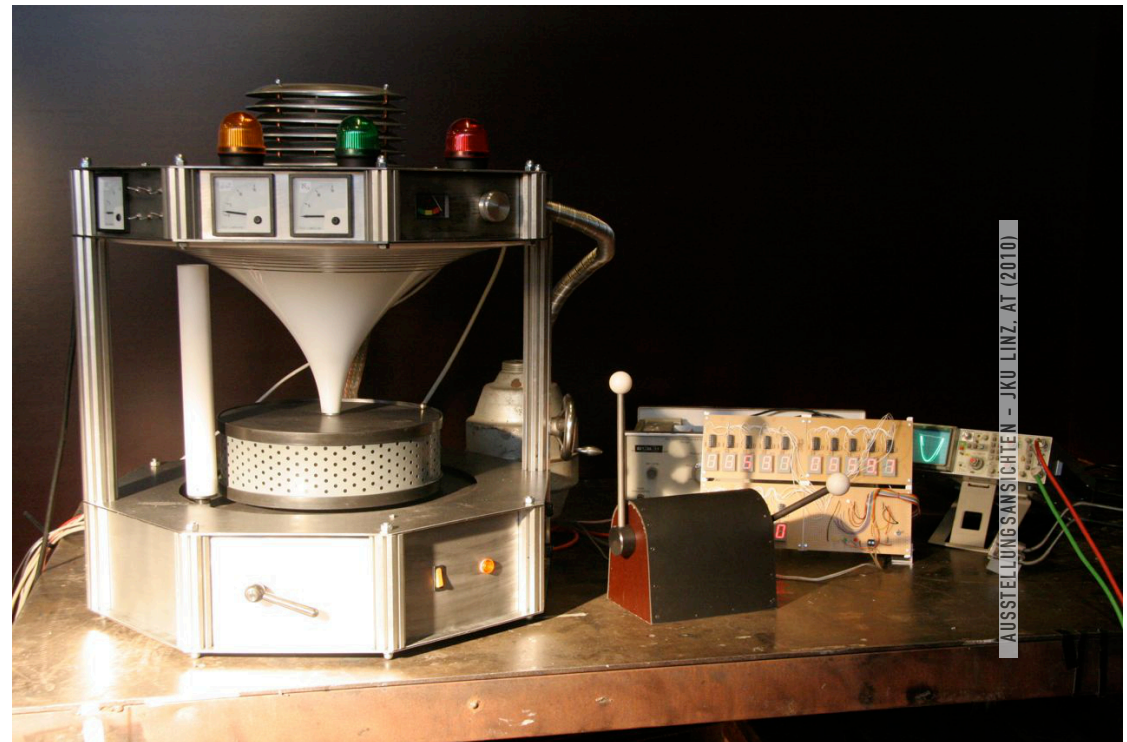

AUSSTELLUNGSANSICHTEN - JKU LINZ, AT (2010)

FRONTALANSICHT

Preis auf Anfrage - info@timesup.org

TIME'S UP QUARTERLY POSTCARDS (2015-2025)

↓ DETAILS ZUM EXPONAT

44 Stück (A6 - 105 x 148 mm) // Kompendium

Permanente Tinte rot & schwarz

Knopfzelle CR 2025 / recycled

Gummizug / recycled



POSTKARTEN - COLLAGE - FÄCHER - DETAIL KNOPF (2025)

FRONTALANSICHT KOMPENDIUM // 2015-2025

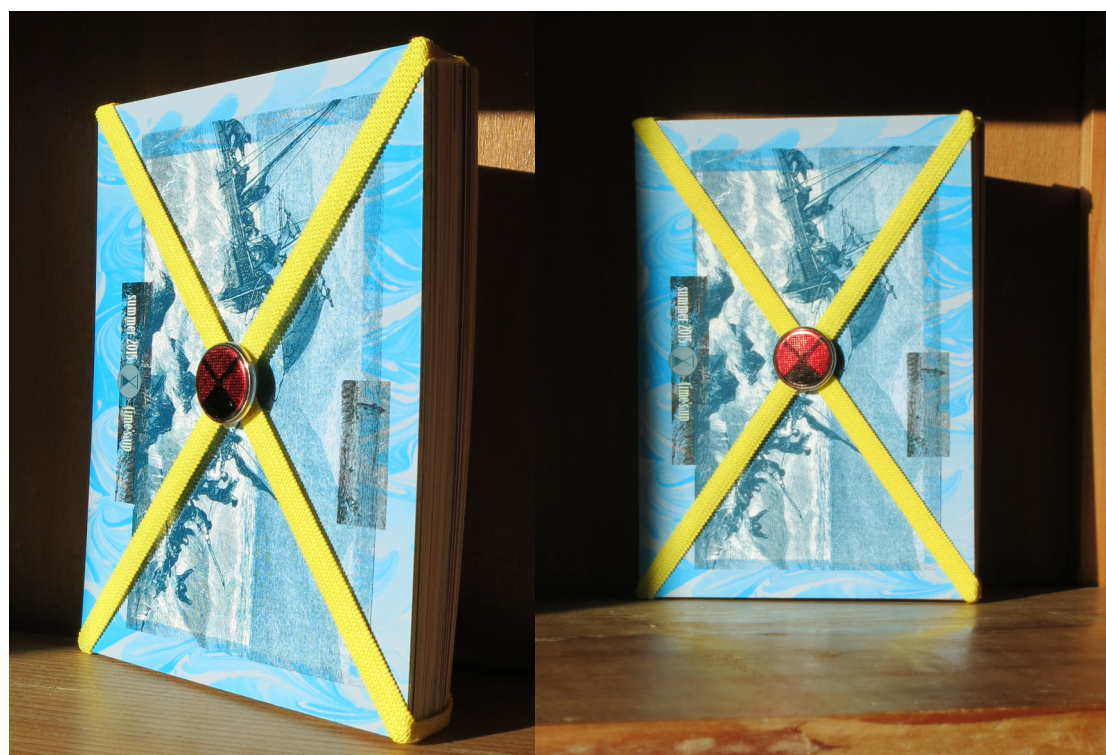

Preis auf Anfrage - info@timesup.org

↓ DETAILS ZUM EXPONAT



THREE HUNDRED AND SIXTY-FIVE SLEEP COINS (2021)

Exponat der Ausstellung 'Work Upside Down'

Galeriesoekel, Plexiglas

Sleep Coins: 365 Stück, Metall, beidseitig geprägt

Dimensionen: 120 cm x 40cm x 40cm (Höhe, Breite, Tiefe)

PRÄSENTATIONSSOCKEL MIT MÜNZEN



MÜNZPRÄGUNG VORDERSEITE



MÜNZPRÄGUNG RÜCKSEITE



AUSSTELLUNGSANSICHT - WORK UPSIDE DOWN IN CLUJ, RO (2021)

Preis auf Anfrage - info@timesup.org

ZEITUNGSSTÄNDER inkl. TURNTON GAZETTE (2017)

Exponat der Ausstellung `Turnton2047`, inkl. 47 Gazetten

Stahlblech blank & Betonsockel, Licht

Turnton Gazette #37: 47 Stück, Druckausgaben auf Zeitungspapier, Tabloid Extra: 305 x 455 mm

Dimensionen: 135 cm x 45 cm x 35 cm (Höhe, Breite, Tiefe); Beleuchtung: 230V

↓ DETAILS ZUM EXPONAT



IMAGE BY: FLORIAN VOGGENHUBER

AUSSTELLUNGSANSICHT - TURNTON DOCKLANDS
LENTOS KUNSTMUSEUM LINZ, AT (2017)



GAZETTENAUSGABE #37

IMAGE BY: ELISA UNGER



DETAIL GAZETTENSTÄNDER
SAMT ZEITUNGEN



AUSSTELLUNGSANSICHT - TURNTON GAZETTE: HOW DARE YOU - ARS ELECTRONICA FESTIVAL (2024)

Preis auf Anfrage - info@timesup.org

↓ DETAILS ZUM EXPONAT



RESCUE!(D) (2015)

Exponat der Ausstellung 'Mind The Map'

Bullaue - Holz, Glas, lackiert

Kinetische Bewegung

Dimensionen: 76cm x 104 cm x 28cm (Höhe, Länge, Tiefe); 230V

BULLAUGE

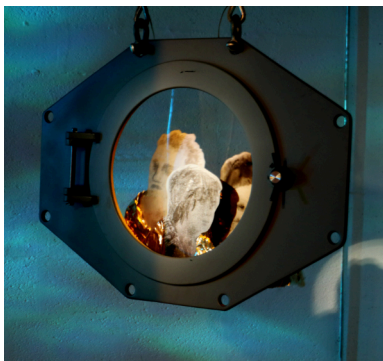
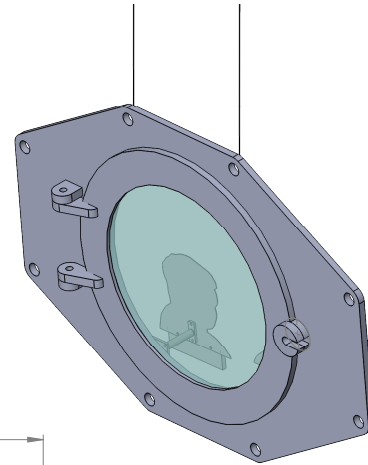

RESCUE!(D)

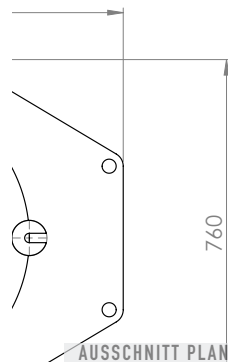

AUSSCHNITT PLANSKIZZE - RESCUE!(D)



AUSSTELLUNGSANSICHT - MIND THE MAP IN SAN VITO, IT (2016)

Preis auf Anfrage - info@timesup.org

CRASH (2015)

↓ DETAILS ZUM EXPONAT

Exponat der Ausstellung 'Mind The Map'

Nachrichtenclip & Ton (Videoarbeit) - C. Kollan

Objekt: PKW-Frontscheibe; sandgestrahlt für Videoprojektion, Drahtseil

Dimensionen: 119 cm x 154 cm x 37 cm (Höhe, Länge, Tiefe); 230V



AUSSTELLUNGSANSICHT - MIND THE MAP IN NANTES, FR (2015)



DETAILANSICHT PKW FRONTSCHNEIBE



verkauft

↓ DETAILS ZUM EXPONAT



TALES OF RESILIENCE (2014)

Widerstandsfähige Reise- und Migrationserzählungen als interaktives Multimediainterface
geöltes Walnussholz, Ebenholzknöpfe, Vintage Radio Gaze,
Industriebildschirm, Stahl brüniert & geschliffen, Frequenzskala,
Lautsprecher, MacMini, Kopfhöreranschluss
Dimensionen: 32,5 cm x 48 cm x 22 cm (Höhe, Breite, Tiefe); 230V



AUSSTELLUNG WIEN, AT (2016)



FRONTANSICHT

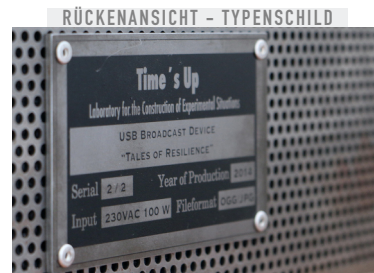

RÜCKENANSICHT - TYPENSCHILD



AUSSTELLUNG VIKTRING, AT (2014)



AUSSTELLUNGSANSICHT - HARARE, ZW (2014)

Preis auf Anfrage - info@timesup.org

UNATTENDED LUGGAGE (2012)

↓ DETAILS ZUM EXPONAT

Familien saga in Form eines interaktiven Multimediainterface
Original Schrankkoffer (Holz, ca. 1920), Leinen tapeziert
Interaktive Radiohörspiele, Minikino, diverse Requisiten/Artefakte
Dimensionen: 129 cm x 55 cm x 45 cm (Höhe, Breite, Tiefe); 230V



AUSSTELLUNGSANSICHTEN - NYC, USA (2012)

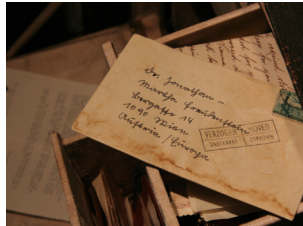

AUSSTELLUNGSANSICHT - CLUJ, RO (2012)

Preis auf Anfrage - info@timesup.org



TIME'S UP
LABOR ZUR SCHAFFUNG EXPERIMENTELLER SITUATIONEN
INDUSTRIEZEILE 33B • A-4020 LINZ
[HTTPS://TIMESUP.ORG](https://timesup.org) • [INFO@TIMESUP.ORG](mailto:info@timesup.org)